

Annotation:

This operation bulletin contains detailed technical description of TM operation performance “Greasing of pivot axles bearings of FDA and pivot pin bearing of FDA”.

Content of changes:

In subsection 5.4.3 “Technical maintenance every 250 hours of operation (2TM-1), every 500 hours of operation (TM-2), every 1000 hours of operation (TM-3), every 2000 (special technical maintenance) hours of operation and technical maintenance which does not coincide with technical maintenance TM-1, 2TM-1, TM-2, TM-3 and special TM timings” the following clause shall be introduced:

5.4.3.3a Operation 36. Greasing of pivot axles bearings of FDA and pivot pin bearing of FDA

To ensure access to grease fittings of pivot axles bearings of FDA it is necessary to dismantle both fenders of front wheels from the tractor.

Dismantle front wheel fender in the following way:

- remove post 3 (figure 5.4.23a) together with fender 4 of the front wheel after unscrewing four bolts 2;
- after removal of post 3, to prevent contamination of threaded holes and losses of hubs 1, reinstall bolts 2.

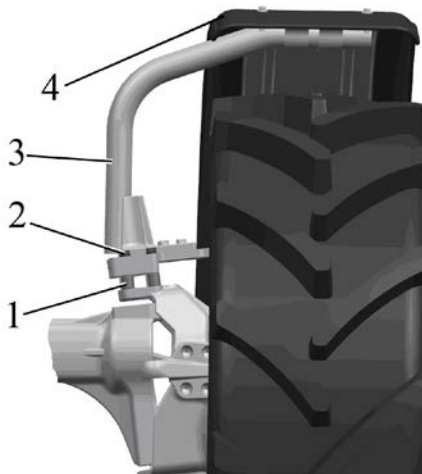

1 – hub; 2 – bolt; 3 – fender post with base; 4 – fender.

Figure 5.4.23a – Front wheel fenders dismantling scheme

To grease pivot axles bearings 3 of FDA (figure 5.4.23b) it is necessary to do the following:

- remove caps 1 from four grease fittings 2 of bearings 3;
- clean grease fittings 2 from dirt and dried grease;
- inject grease fittings 2 with grease, by performing from 4 to 6 injections.

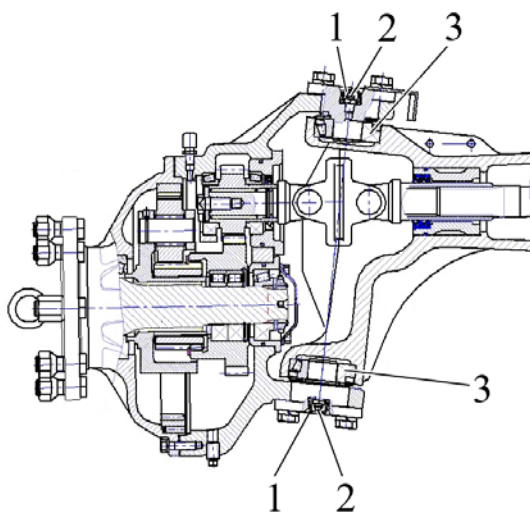

1 – cap; 2 – grease fitting; 3 – bearing.

Figure 5.4.23b – Greasing of pivot axles bearings of FDA

After greasing pivot axles bearings of FDA retro-mount fenders 4 (figure 5.4.23a). Tighten bolts 2 with a torque of 67 to 85 N·m.

To grease FDA pivot pin bearings 3 (figure 5.4.23c) perform the following:

- clean grease fitting 4 from dirt and dried grease;
- inject grease fitting 4 with grease until it appears from the clearances.

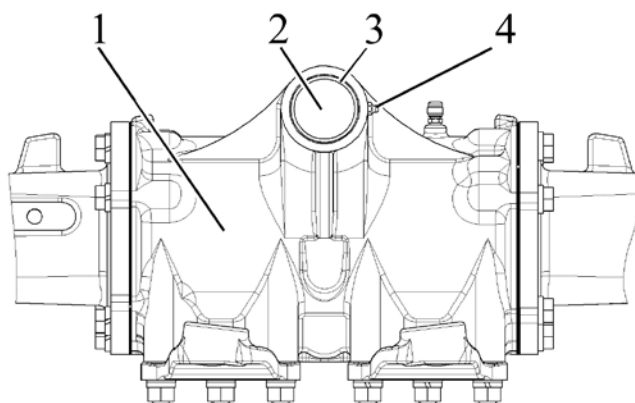

1 – FDA; 2 – FDA pivot pin; 3 – bearing; 4 – grease fitting.

Figure 5.4.23c – Greasing of pivot pin bearings of FDA (tractor front view)

When using grease MC-1000 TU 0254-003-45540231-99 the operation “Greasing of pivot axles bearings of FDA and pivot pin bearing of FDA” shall be performed every 500 hours of tractor operation.